

RCP Can-V2

Installation Manual

Figure 1

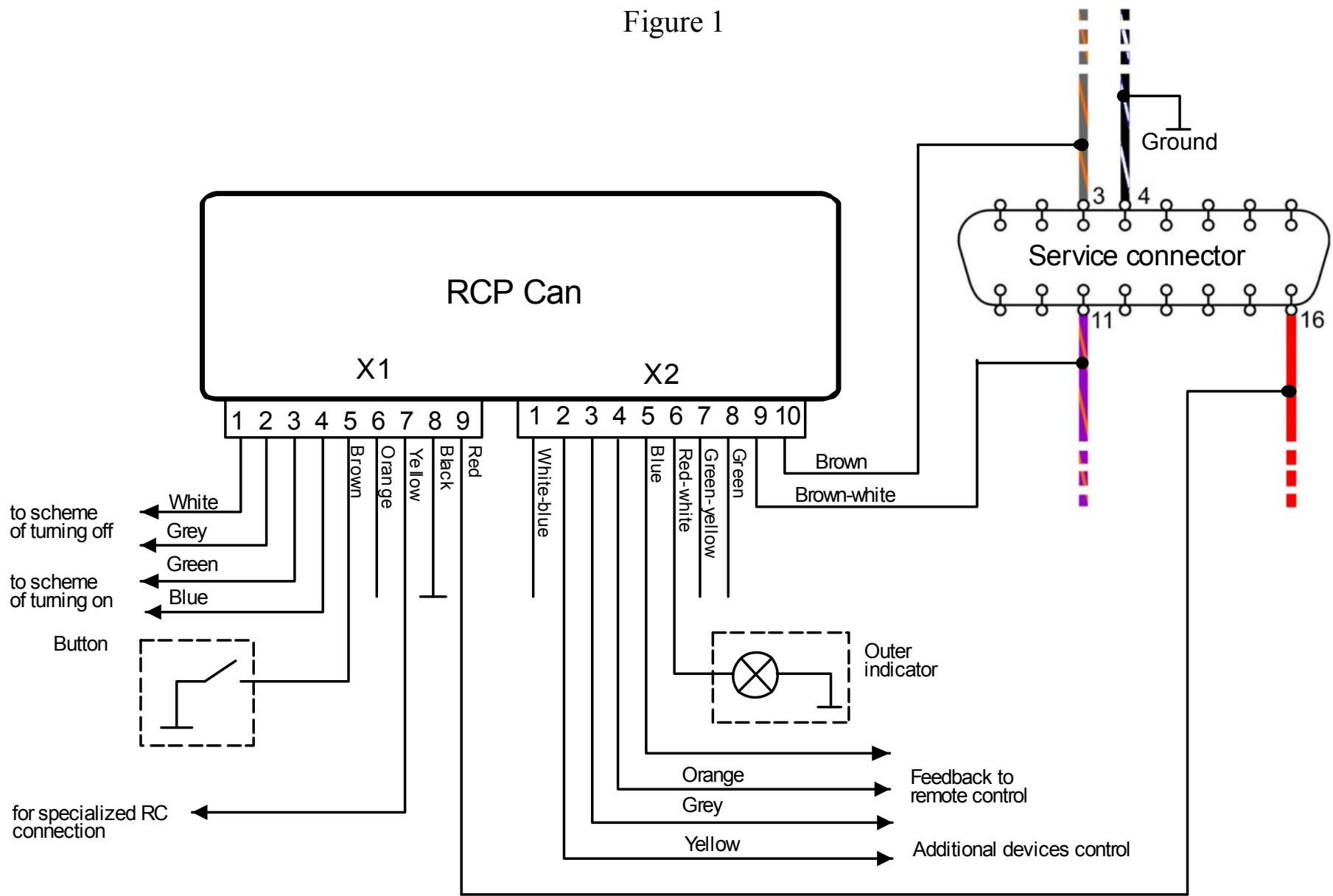

Table of Contents

Installation procedure for plug-n-play connection.....	3
Connection schemes for permanent connection	3
Installation procedure for permanent connection.....	6
Troubleshooting.....	7

1) Installation procedure for plug-n-play connection

- Open the case of the service connector at the left side of the dashboard, below the lighting control switch (not applied to the XC60)
- Pass PnP-cable wires with white connectors on the end inside the dashboard, beside of the service connector. Pull the wires into the dashboard.
- Connect white connectors of PnP-cable to RCP Can
- Connect big black connector of PnP-cable to the car's OBD-connector.
- Turn ignition on to let the module get information from CAN-bus and wait until LED goes off. Turn ignition off.
- Check for the heater remote start with original Volvo key: turn on perimeter lighting, then press Lock button twice.
- Find a place under the dashboard for the module and fix it with adhesive tape.
- Shorten length of the cable by the strap
- Close the case of the service connector (not applied to the XC60)

Note: if you need to unplug PnP-cable from OBD-connector (ex. to connect diagnostic equipment to the vehicle's electronic system), don't pull for the wires of the cable! Pull for the housing of black connector.

2) Connection schemes for permanent connection

- **General connection scheme** (fig.1, page 2)

Explanations to the scheme:

- It is enough to connect power wires (X1.8, X1.9) and CAN-bus wires (X2.9, X2.10) to the module to obtain a possibility to start the heater by Volvo key. You can use supplied PnP-cable for such a connection.
- The car's wiring marked in colour.
- Optional elements are outlined by dashes

- **Connection of the inputs Heater_on± and Heater_off±**

You can connect and use a set of devices as a remote control of your fuel-fired heater: specialized heater remotes (such as Telestart, EasyStart, Smart Start), additional alarm systems remote controls, GSM mobile phones in conjunction with automotive GSM-modules, etc.

If your remote control has output channels that give short impulses in active state, it is possible to apply the schemes given at fig. 2-6. The remote control with two independent channels can separately turn the heater on and off.

- The fig.3 presents the scheme to turn the heater on by the impulse of positive polarity. The fig.4 presents the scheme to turn the heater on by the impulse of negative polarity.

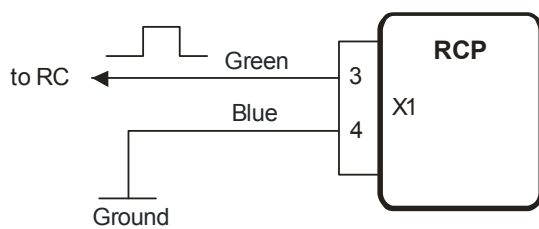

Figure 2

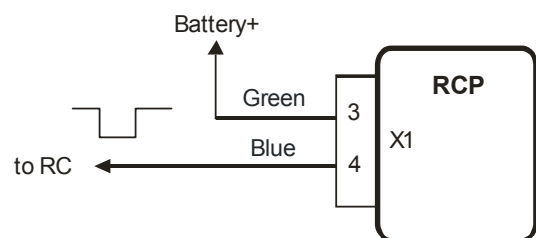

Figure 3

- The fig.4 presents the scheme to turn the heater off by the impulse of positive polarity. The fig.5 presents the scheme to turn the heater on by the impulse of negative polarity.

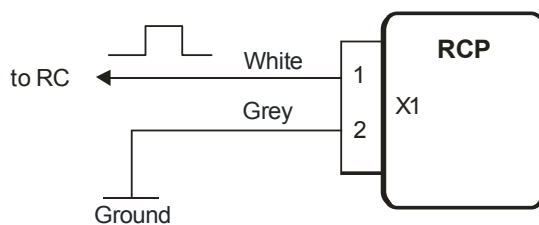

Figure 4

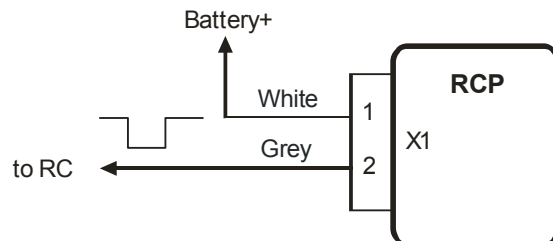

Figure 5

- The remote control with the only one output channel may be connected by the scheme at fig. 6 to add a possibility not only to turn the heater on, but also turn the heater off too. Every one impulse on the output of the remote control receiver unit will move the heater to the opposite state: switch on the idle heater, switch off the operated heater. To realize this mode it is necessary to connect in pairs the inputs Heater_on+ with Heater_off+, and the inputs Heater_on- with Heater_off-.

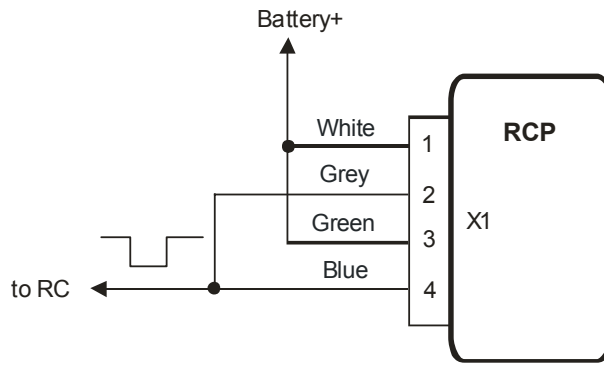

Figure 6

- **Connection of the input RC_in**

- The input RC_in is intended for the connection of specialized remote controls such as DEFA Smart Start, Hydronic Easy Start, Webasto Telestart. If a problem exists with direct connection of the remote control output line to the input RC_in, it is recommended to make a connection by the scheme at the fig.7.

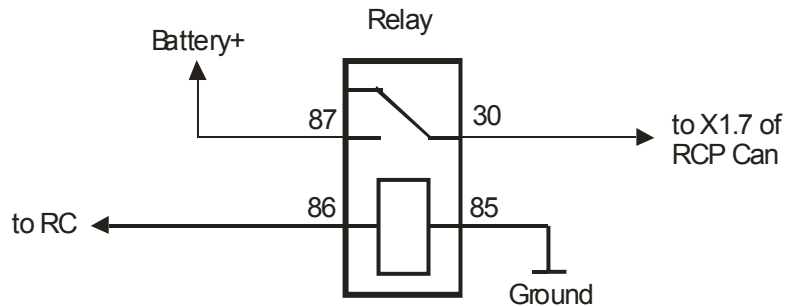

Figure 7

- Some GSM modules can control an additional device through the inner relay. They may be connected to RCP Can by the scheme at the fig.8

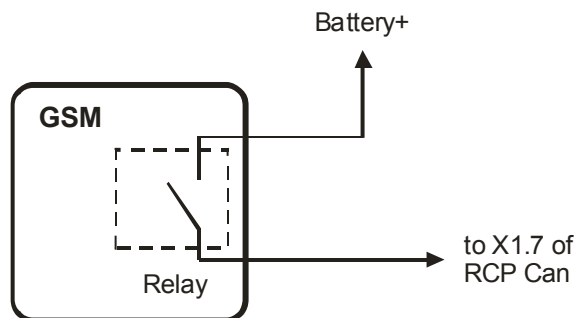

Figure 8

- **Alerts receiving**

If remote control unit has got inputs to obtain information about the heater operation, they can be connected to the RCP Can outputs Alert_1 and Alert_2. The outputs have negative polarity. Therefore if remote control unit not fit it, it needs to apply a matching circuit (with relay ex.).

Events given on the outputs Alert_1 and Alert_2 are adjusted by the settings 7.3 and 7.4 accordingly. Also the RCP output line Timer_out can be used as a notification how much time the heater operates.

- **Status output line application**

1. Indication of the heater operation by the hazard warning flashers (for the vehicles not equipped by the turn signals in rear-view mirrors).

The module can indicate of the heater operation by hazard flashers. Connect the module's output X2.2 to the grey-red wire (pin 3 of the connector) of the hazard warning switch, and choose the settings 7.5.3 (the settings 6.2-6.7 also need to be adjusted) for this purpose.

3) Installation procedure for permanent connection

- **General recommendations**

The required tools: Torx screwdriver, wire cutter, wire stripper.

- Remove the panel around the service connector on the left side of the dashboard
- Find a place inside the dashboard to install the module (mounted on double-sided tape)
- Connect the module to the vehicle's wiring according to the scheme at the fig.1. Connect the module to the receiver unit of remote control, according to the schemes at the figures 3-9. Make task specific connections, if necessary. The module is powered and connects to the CAN-bus wires near the service connector by quick splice connectors (supplied).

The module's power (pin X1.9) connects to the red wire of service connector (pin 16), the module's signal ground (pin X1.8) – to the brown wire of service connector (pin 4).

The signal «CAN-L» (pin X2.9) connects to the violet-orange wire (pin 11), the signal «CAN-H» (pin X2.10) – to the grey-orange wire (pin 3). Twist the brown and brown-white wires of the connector X2 to the pair before connections. It is not recommended to lengthen these wires.

- Connect both connectors to the module (X2 should be connected first)

- Test the heater start by the module's command
- Fix the module using double-sided adhesive tape
- Install interior elements in the reverse order of removal
- Adjust the module in programming mode if it necessary. Make notes in the programming table of the user manual about the adjustments

4) Troubleshooting

If you have problems with the module's operation, first of all check indication of the built-in LED. After power connection, LED will turn on for a 1 second and then has to turn off. In the programming mode LED lights continuously. If a run-time error appears at the heater start, LED will indicate an error by flashings. The number of flashes corresponds to the error code. See table 1 for the codes description and possible solutions.

Table 1

Error Code	Error Description	Possible Reasons of Error Appearance	Solutions
1	Wrong heater configuration	The heater is not activated in DIS	Configure the heater by Volvo car dealer equipment
2	No answer from the heater followed the start command	The heater hasn't finished previous cycle of operation yet (you can hear the noise from the air blower fan)	The heater will startup after previous cycle of operation will be fully completed
		Fuel level in the tank is close to empty ("Fuel Low" warning indicator is lighting in DIS)	Refuel your vehicle
		The heater is blocked after 3 unsuccessful starts	Try to start the heater from DIS menu. If it not started to burn, make a diagnostics of the heater.
		The module has determined that the battery voltage at the heater startup or during the heater operation is below the specified settings 3.1 и 3.2	Charge vehicle's battery with special charger (or start engine to charge) or cancel 3.1/3.2 module's settings

4	Time limits exceeded	Time limit for autonomous operation of the heater is achieved (with active setting 1.1)	Run the engine or cancel 1.1 module's setting
5	Unsuccessful start	The heater was switched off spontaneously at a startup	Make a diagnostics of the heater if the error is repeated
6	Operation cycle too short	The heater was switched off spontaneously with operating time of less than 20 minutes	Make a diagnostics of the heater if the error is repeated
8	CAN-bus error	The lines X2.9 и X2.10 connected incorrectly	Check the lines connection
9	Settings error	Settings have been incorrectly stored in RCP memory	Reset the settings (8.1.1), readjust RCP
10	Wrong command	Start command can not be executed because the heater is operated yet	Check the connection of the input lines "Heater_on" and "Heater_off"
11	Heater no connection	The heater is unplugged from CAN-bus or is out of order	Make a diagnostics of the heater