

Autoplugin RCP-F4

Installation Manual

Figure 1

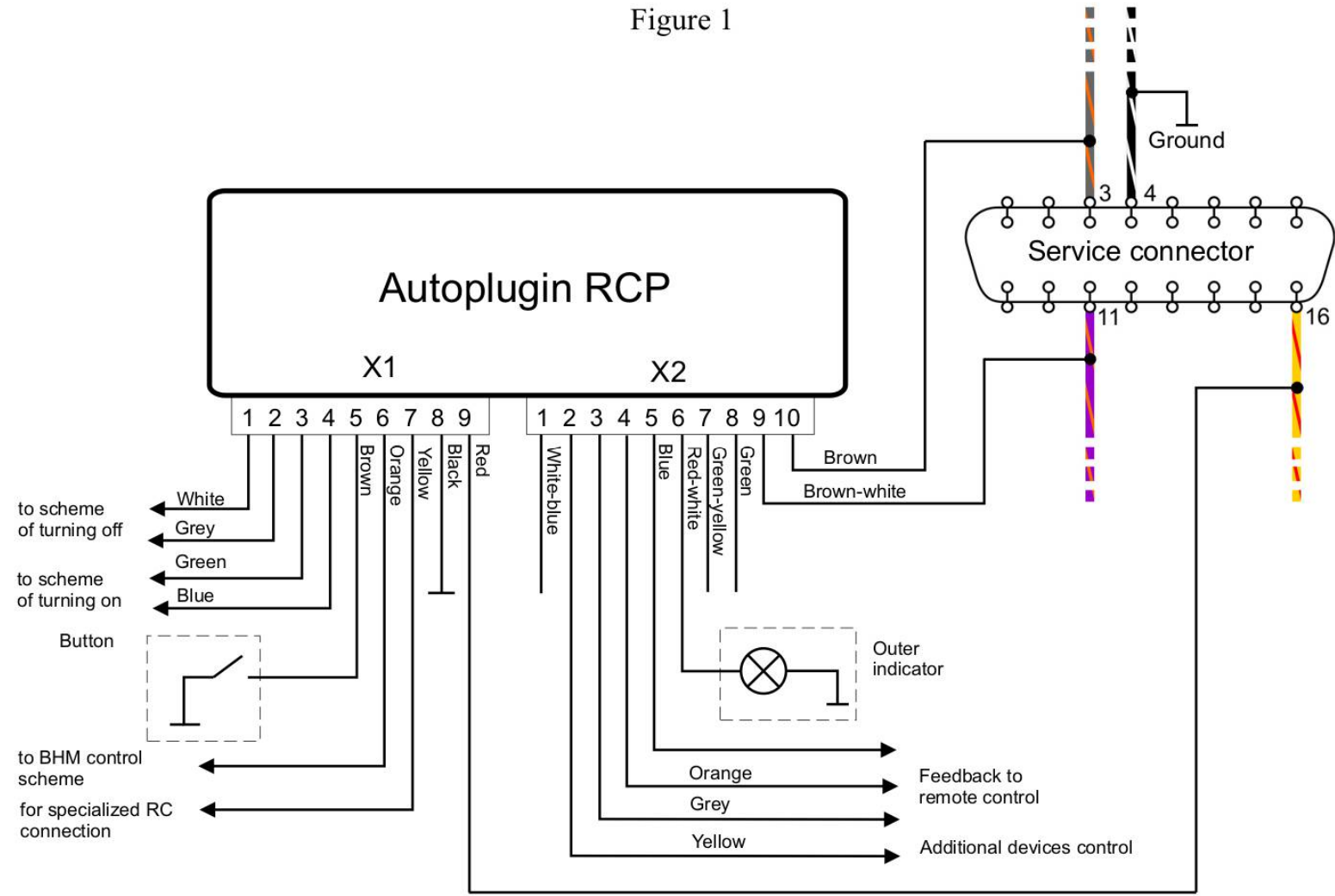

1) Connection variants

It is enough to connect supply wires (X1.8, X1.9) and CAN-bus wires (X2.9, X2.10) to the module to obtain a possibility to start the heater by Ford key. It can be made by using plug-n-play cable (quick connection) or by using quick splice connectors (permanent connection). If you wish to connect additional remote control, permanent connection is recommended.

2) Permanent connection schemes

- **General connection scheme** (fig.1, page 2)

Explanations to the scheme:

- The car's wiring marked in colour.
- Optional elements are outlined by dashes

- **Connection of the inputs Heater_on± and Heater_off±**

You can connect various remote control devices for heater remote control: specialized heater remotes (such as Telearstart, EasyStart, Smart Start), additional alarm systems remote controls, mobile phones in conjunction with automotive GSM-modules, etc.

If remote control device has got output channels that give short impulses in active state, the schemes given at fig. 2-6 may be used. The RC with two output channels can separately turn the heater on and off.

- The fig.2 presents the scheme to turn on the heater by the impulse of positive polarity. The fig.3 presents the scheme to turn on the heater by the impulse of negative polarity.

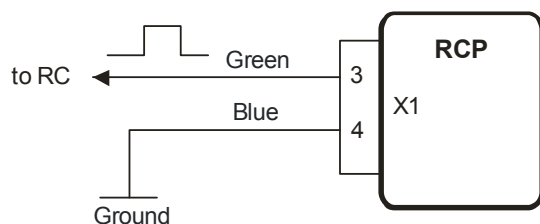

Figure 2

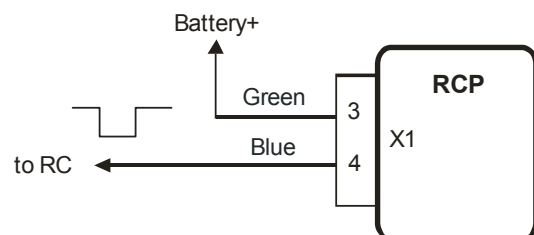

Figure 3

- The fig.4 presents the scheme to turn off the heater by the impulse of positive polarity. The fig.5 presents the scheme to turn off the heater by the impulse of negative polarity.

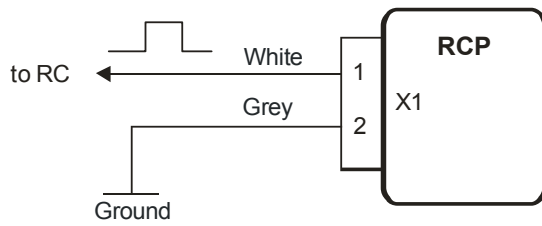

Figure 4

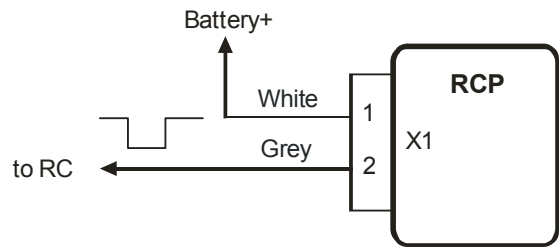

Figure 5

- The remote control with only one output channel may be connected by using the scheme at fig. 6. The scheme provides possibility not only to turn the heater on, but also to turn the heater off. Every one impulse on the output of the remote control receiver unit moves the heater to opposite state: switch on idle heater, switch off operated heater. To realize this mode it is necessary to connect in pairs the inputs Heater_on+ with Heater_off+, and the inputs Heater_on- with Heater_off-.

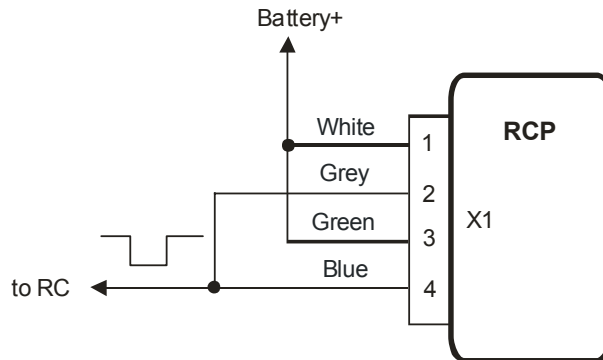

Figure 6

- **Connection of the input RC_in**

- The input RC_in is intended for connection of specialized remote control devices such as DEFA Smart Start, Hydronic Easy Start, Webasto Telestart. If direct connection of RC's output control line to the RCP's input line RC_in is not functional, try the scheme at the fig.7.

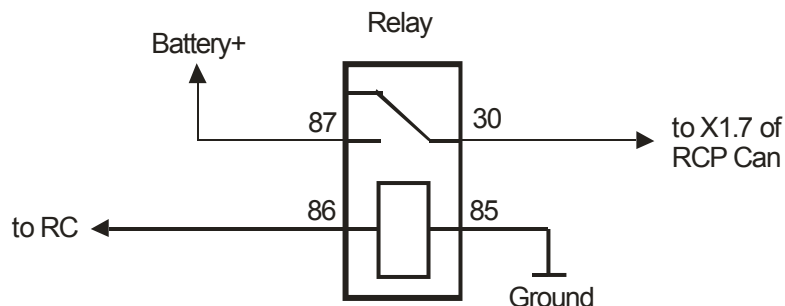

Figure 7

- Some GSM modules control additional device by the means of embedded relay. These may be connected to RCP using the scheme at the fig.8

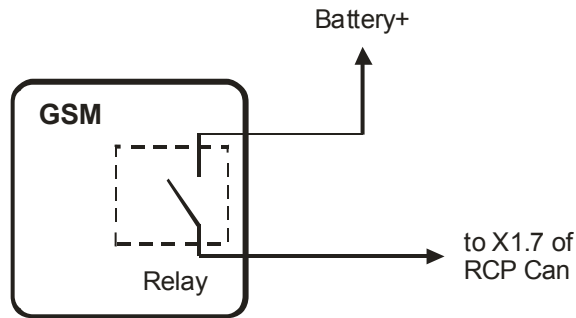

Figure 8

- **Alerts receiving**

If remote control unit has got inputs to obtain information about the heater operation, these can be connected directly to the RCP outputs Alert_1 and Alert_2. The outputs are negative polarity. If RC's inputs have positive polarity, it needs to apply a matching circuit (with relay ex.).

Events given on the outputs Alert_1 and Alert_2 are adjusted by the settings 7.3 and 7.4 accordingly. Also the RCP output line Timer_out can be used as notification how much time the heater operates.

- **Status output line application**

1. Indication of the heater operation by the all hazard warning flashers

The module can indicate of the heater operation by hazard flashers. Connect the module's output X2.2 to the brown-yellow wire (pin 6 of the connector) of the hazard warning switch, and choose the settings 7.5.3 (the settings 6.2-6.7 also need to be adjusted) for this purpose.

3) Installation procedure for permanent connection variant

- **General recommendations**

It is highly recommended to disconnect the main battery before the installation in case of permanent connection. Note that battery disconnection may reset power windows settings, heater settings in DIS, and also the radio unit requires entering the code after the battery reconnection. See vehicle's User Manual for details.

- Open the service connector's case at the left side of the dashboard, below the lighting control switch
- Find place inside the dashboard to install the module (mounted on double-sided tape).
- Connect the module to vehicle's wiring according to the scheme at the fig.1. Connect the module to the receiver unit of remote control, according to the schemes at the figures 3-9. Make task specific connections, if necessary. The module is powered and connected to CAN-bus wires near the service connector using quick splice connectors (supplied). The backside view of the service connector presented at the fig.9.

Module's power (pin X1.9) connects to the yellow-red (yellow with red stripe) wire of service connector (pin 16), the module's signal ground (pin X1.8) – to the black-white wire of service connector (pin 4).

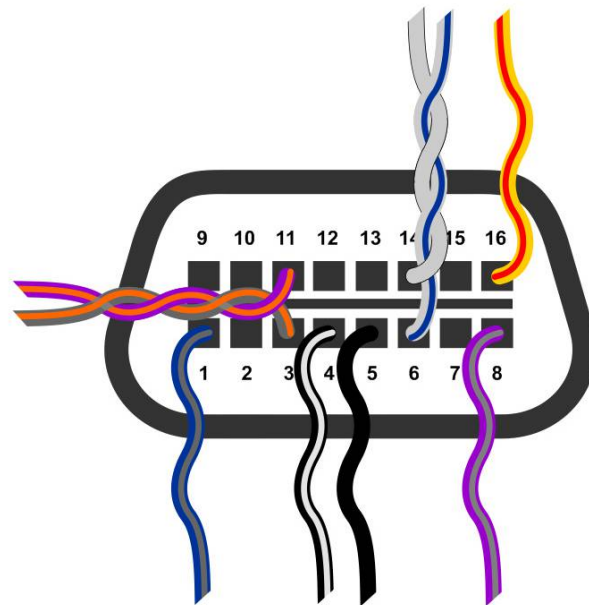

Figure 9

The signal «CAN-L» (pin X2.9) connects to the violet-orange wire (pin 11), the signal «CAN-H» (pin X2.10) – to the grey-orange wire (pin 3). Twist brown and brown-white wires of module's connector X2 to the pair before making connections. It is not recommended to lengthen these module's wires.

- Connect both connectors to the module (X2 should be connected first)
- Connect vehicle's battery (if it has been disconnected before)

- Turn the ignition on to let the module get information from CAN-bus. Wait until the LED goes off.
- Test heater start by using remote controller or car's remote control key.
- Fix the module using double-sided adhesive tape
- Adjust the module in Setup mode if necessary. Make notes in the programming table of the User Manual about adjustments have been made.

